

User instructions for the 100" HoloPro™ screen

1. Instructions for overhead use of the 100" screen

The 100" screen with its stainless steel frame is authorised for overhead use.

Building Law regulations must be observed for the mounting points in the ceiling and for the suspension. If a building authorisation is required, the screen can only be suspended using the authorised tension bars if no additional proof is provided. In Germany there is no building authorisation for the fixed installation with wire cables.

In addition, the load-bearing capacity of the ceiling mounting must be tested and a suitable and authorised connection must be chosen. The suspension load is approximately 150 kg.

These regulations do not apply when equipment is set up for a short period of time (on the fly). Generally the necessary constructional conditions must be checked and observed: special regulations can apply to use in public areas and for trade fairs (depending on location). When used outside Germany the Building Law of the respective country applies.

2. General

2.1. Screen (without frame)

The 100" HoloPro™ screen consists of a laminated glass screen made of 4 and 6 mm float glass with an antireflective surface and a holography film inset. The picture format is 2 x 1.5 metres. The foil is surrounded by a 35 mm-wide glass rim, which protects the holographic film against moisture penetration.

When setting up or framing the screen it should be ensured that it does not come into direct contact with material which is as hard or harder than it. Also points or lines of pressure on the glass surface should be avoided.

The glass edges can be subjected to a load spread across a wide area but not to one where certain points are subjected to a load.

The care instructions for antireflective glass surfaces should be observed.

2.2. General installation of the screen (without frame)

The screen may be used in a vertical position or inclined by up to 15° at eye level (the centre of the screen at a maximum of 1800 mm above the floor) without any special construction measures. People are not allowed to be under the screen. If necessary, the area should be cordoned off or surrounded with railings.

If the screen is damaged (cracks, pieces broken off or fallen off, etc.) the screen should no longer be used and must be exchanged. This applies to even the smallest amount of damage.



3. The stainless steel frame for overhead use

3.1. The frame

The stainless steel frame consists of extremely strong stainless steel profiles with a width of 30 mm. It is attached to the screen with adhesive at the manufacturer and hence forms a static unit. Type statistic is available for it in accordance with German regulations. Appropriate breaking tests were carried out at Darmstadt Technical University. The unit has been tested and approved for overhead use in the tilting range from 0 to 15° out of the vertical plane.

3.2. Mounting points

On each of the short sides there are M6 threaded holes (Fig. 3.2.2) for attaching a milled stainless steel eye hook as a mounting point. These borings have been carried out in such a way that an inclination of 0°, 5°, 10° and 15° can be selected by choosing the right holes. On the upper and lower side of the long sides there also M6 screw threads, which are for the vertical suspension. The eye bolts supplied with the screen can be used for this. All borings have been mirrored on the opposite side so that projection is not only possible from above but also from below.

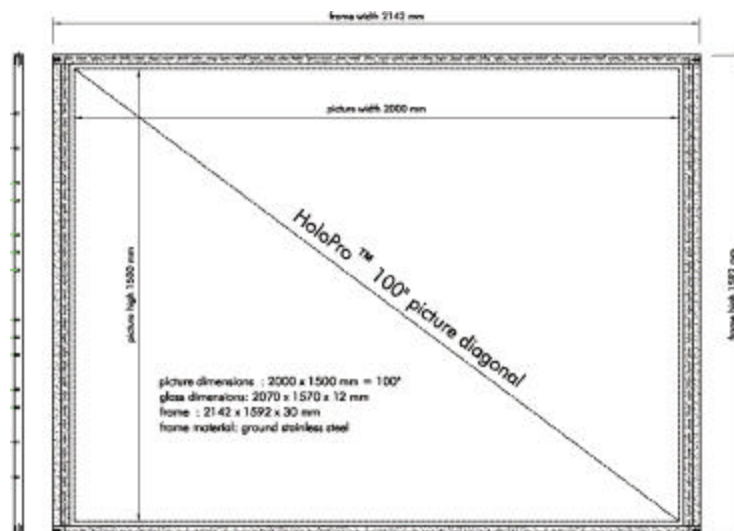

Fig.3.2.1

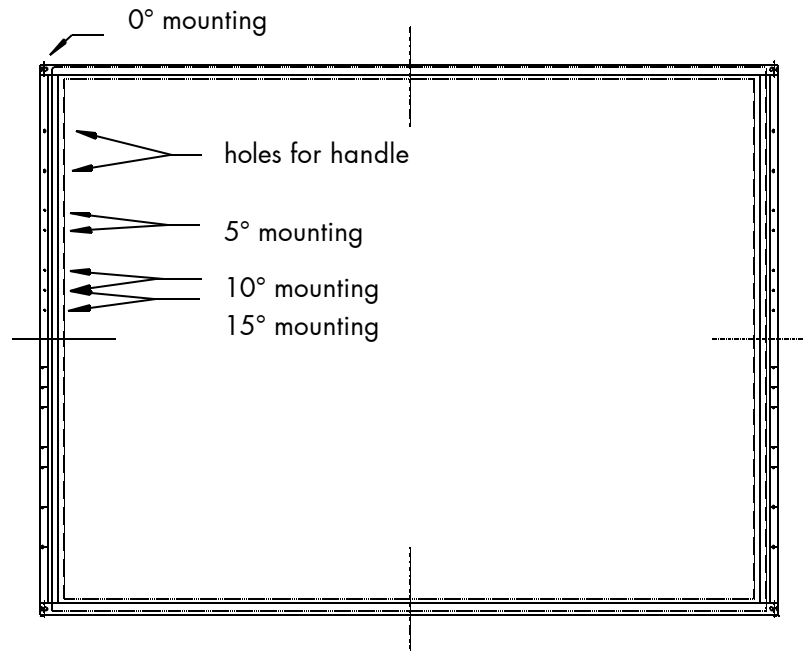

Fig. 3.2.2.

3.3. Inclination mounting

2 high-quality, stainless steel, milled eye hooks (Fig. 3.3.1) are supplied with each of the M6 x 15 mm screws which have a strength class of A 4.70 and these are fixed to the envisaged points on the left and the right of the frame. Only this combination qualifies for a valid authorisation. Only elements which have an authorisation for the carrying load of the screen and application-specific securities are allowed to be attached to these mounting points.

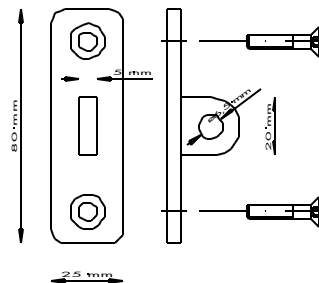

Fig. 3.3.1

details mounting point

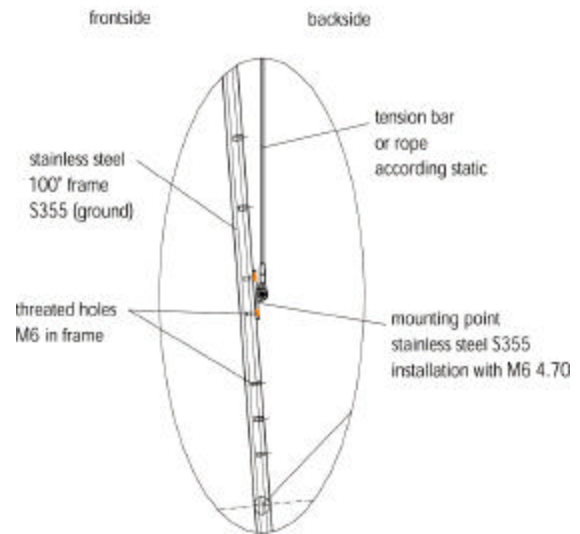

Fig. 3.3.2.

3.4. Ceiling points

The mounting points in a ceiling must be tested for their load-bearing capacity in each individual case. Project-specific authorisations may be necessary.

3.5. Inclination mounting points

The mounting points of the frame are designed for the inclinations 0°, 5°, 10° and 15° (Fig. 3.2.1). To prevent the screen from swaying, additional inclination mounting points are offered for 10° and 15°(Fig. 3.5.1 + 3.5.2.).

Fig. 3.5.1

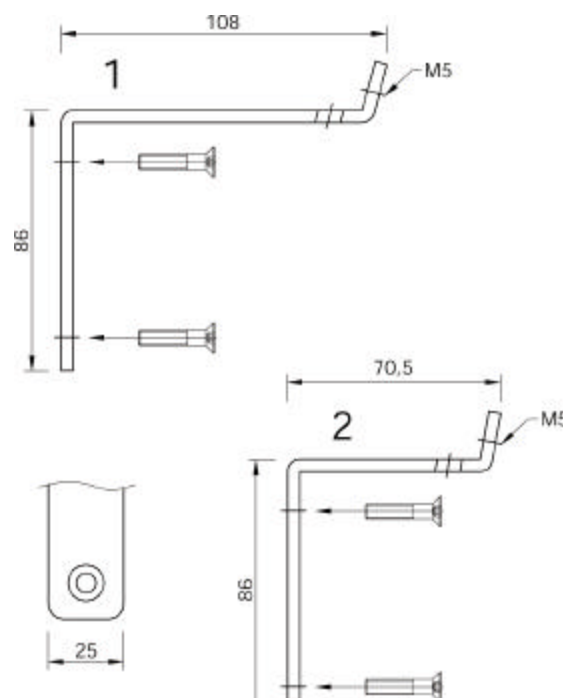



Fig. 3.5.2.

3.6. Carrying handles

Carrying handles which are available as accessories (Fig. 3.6.1. and 3.6.2.) can be screwed into two M8 threaded holes on each of the short sides.

Fig. 3.6.1.

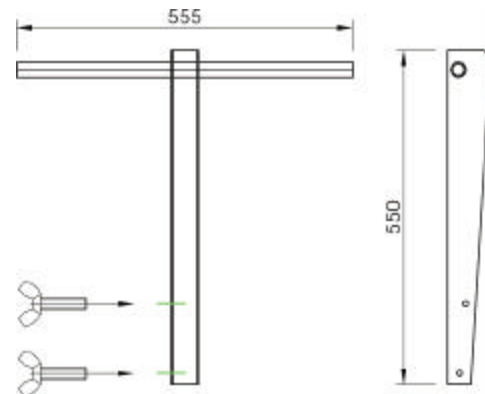

Fig. 3.6.2.

4. Standard geometry of the 100" HoloPro™ screen

